

MPT-28580 1/2" Reversible Air Drill (650 r.p.m.)

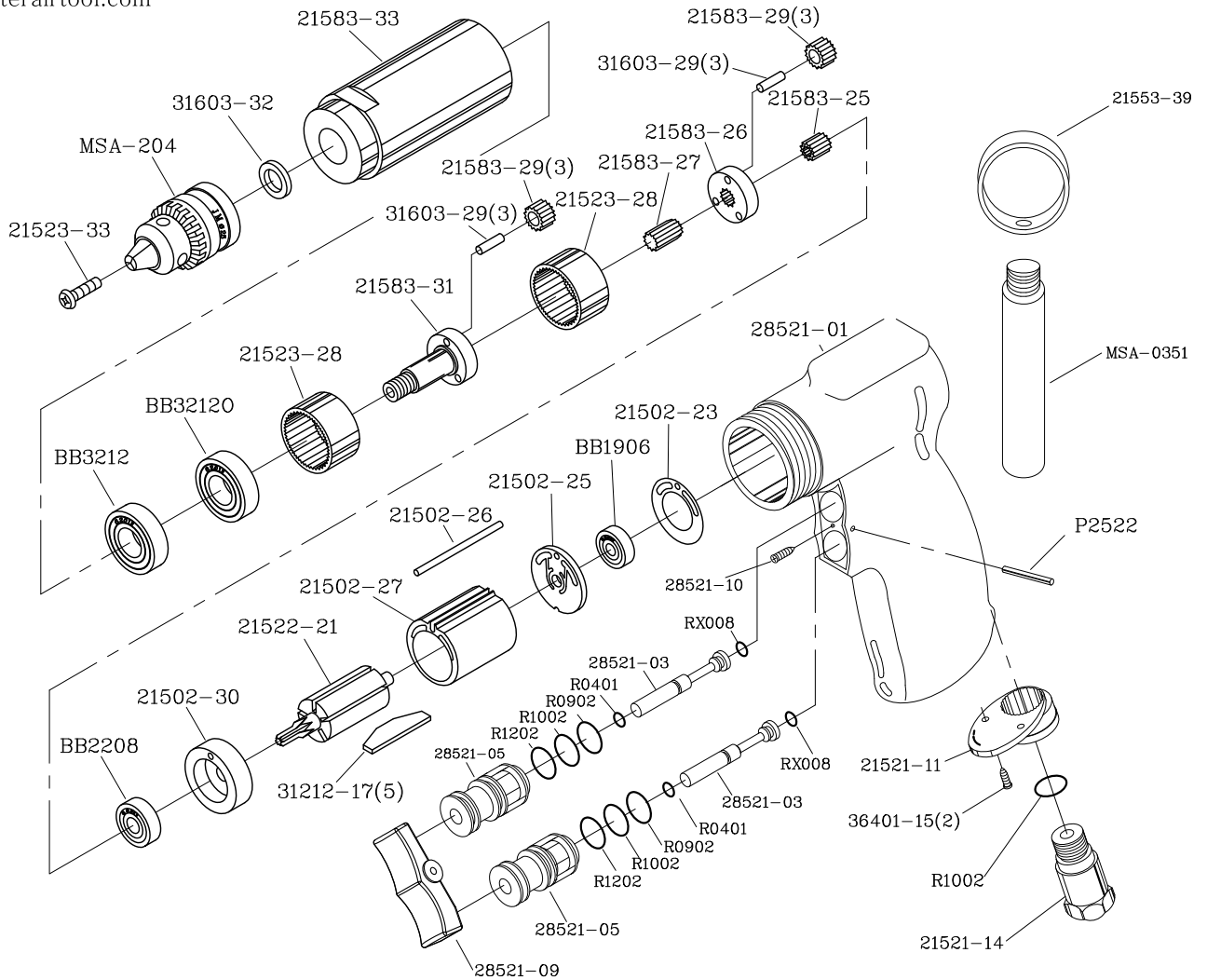

DESCRIPTION	PARTS NO.	DESCRIPTION	PARTS NO.
MOTOR HOUSING	28521-01	CYLINDER	21502-27
O RING (2)	RX008	ROTOR	21522-21
THROTTLE VALVE (2)	28521-03	ROTOR BLADE (5)	31212-17
O RING (2)	R0401	FRONT END PLATE	21502-30
O RING (2)	R0902	BEARING	BB2208
REVERSE BUSHING (2)	28521-05	PLANET CONNECT GEAR	21583-25
O RING (2)	R1002	BACK OF PLANET GEAR SEAT	21583-26
O RING (2)	R1202	TRANSMISSION GEAR	21583-27
TRIGGER	28521-09	PLANET GEAR SPINDLE (6)	31603-29
EXHAUST SLEEVE	21521-11	PLANET GEAR (6)	21583-29
TRIGGER SCREW	28521-10	INTERNAL GEAR (2)	21523-28
CIRCLE OF SCREW (2)	36401-15	FRONT OF PLANET GEAR SEAT	21583-31
O RING	R1002	BEARING	BB3212
AIR INLET	21521-14	CLAMP NUT	21583-33
SPRING PIN	P2522	WASHER	31603-32
MOTOR GASKET	21502-23	CHUCK	MSA-204
BALL BEARING	BB1906	CHUCK SCREW	21523-33
REAR END PLATE	21502-25	SK5 SPANNER WRENCH	WO319
PIN	21502-26	CLAMP	21553-39
BEARING	BB32120	CLAMP SHAFT	MSA-0351